

4 CYLINDERS MOULDERS

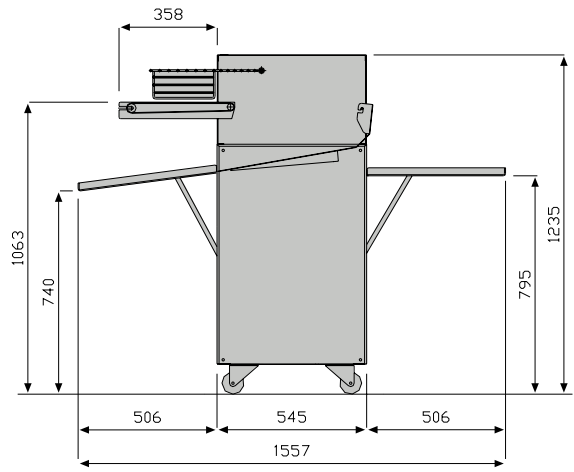

- St/st construction
- Strong aluminium shoulders 15 mm thick grant stability and precision to the divider and to the moulders
- Blue antimicrobial infeed belt
- Sheeting adjustment by scrapers with springs
- Moulding adjustment:
upper belt with spring stretcher and adjustable anti-swerve device on lower belt with spring stretcher.
- Device to lift upper belt and get a wide opening between belts
- Disengagement device for upper moulding belt
- Collecting tables on both sides to discharge products from both sides of the moulder
- 4 wheels
- Electric system and panel as per EN60204; insulation as per IP54
- Safety guards with limit switches to stop the machine
- All materials coming in contact with the product fulfill all hygiene requirements



Loaves moulders st/st with moulding table

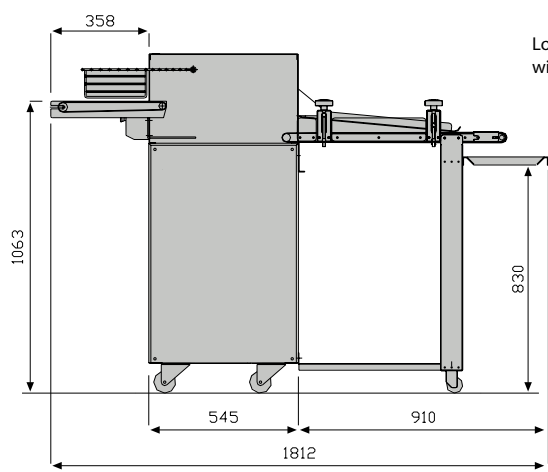

Loaves moulders st/st without moulding table

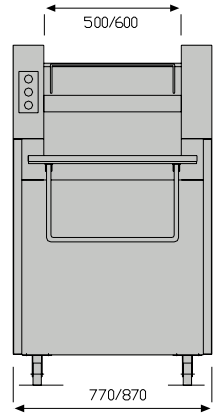

	Weight per piece	Cylinder width	Power	Weight	Voltage
	g	mm	kW	kg	V~/Hz
FM-S-4C 500	30÷750	500	0,75	155	V400/3~/50Hz
FM-S-4C 600	30÷750	600	0,75	190	V400/3~/50Hz