

ROTO AVANT



- Modular steam generator, with cascade elements with spheres
- Steamers with automatic feed
- Hood with potentiated exhaust fan
- Door with double glass and double closing
- Heat exchanger with armored heating elements (SE)
- Standard rotation device with hook
- Electric board with extended cables to hang it on oven's sides
- Oven with burner on the right is available (optional)(Excluded 80120)
- Preset for automatic lifting group by lever (optional) (Excluded 80120)
- Racks height 1925 mm

Power inlet	400/3N~/50
Fume exhaust	Diameter 200 mm
Steam exhaust	Diameter 250 mm

ROTO AVANT HR 6080

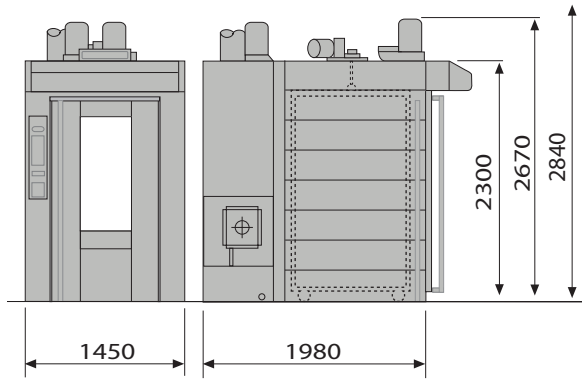

ROTO AVANT HR 80100

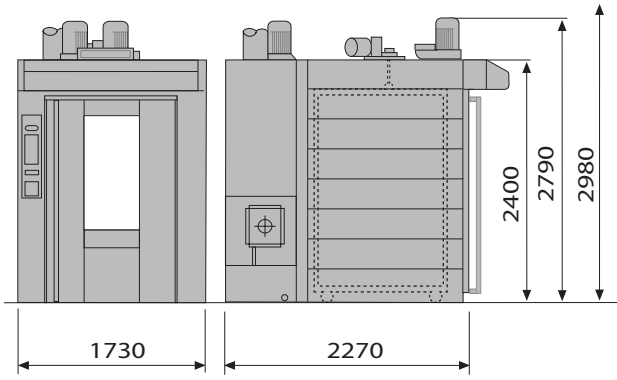

ROTO AVANT HR 80120

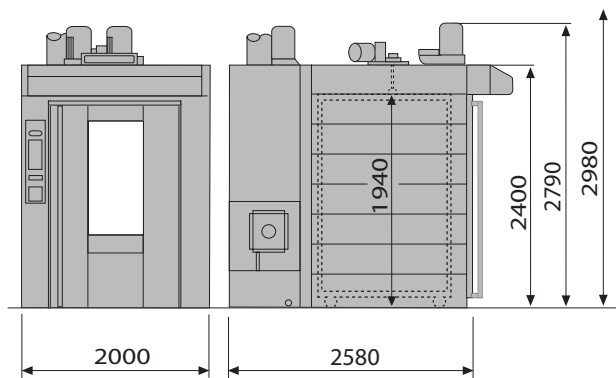

	Pan capacity	Pan size	Minimum door width	Weight	Voltage	SC version		SE version	
						kW	kcal/h	Standard	Potentiated
	n°	passo	mm	mm	kg			kW	kW
ROTO AVANT HR 6080	16	105	600x800	500	1450 SC	2,0	60.000	48,8	58,5
	18	93	2x600x400		1400 SE				
ROTO AVANT HR 80100	16	105	800x1000	840	1900 SC	2,5	80.000	63,0	-
	18	93			1850 SE				
ROTO AVANT HR 80120	16	105	800x1200	800	2220 SC	2,8	95.000	81,0	-
	18	93	2x600x800		2150 SE				