

WIND

- 4060/5
- 4080/5
- 4666/5
- 6040/5
- 4060/10
- 4080/10
- 4666/10
- 4060/9
- 6040/9



- Computer MULTIBAKE 100 programs
- Weekly automatic start
- Electric board removable from the front for easy maintenance
- Halogen lamps on the door, easy to change, without tools
- Sprayed water steamer
- Door with double glass

PROOF BOX

- Armored electric element with thermostat for heating
- Water basin with ball-cock and electric element for humidity
- Inner ventilation for even air distribution
- Sliding tray support in the front
- Electro-mechanical keyboard

Line feeder	400/3N~/50 Unico 4060/5 230/1~/50 cell
Water Inlet	Diameter 3/8"
Water discharge	Diameter 1/2"
Steam exhaust	Diameter 80 mm

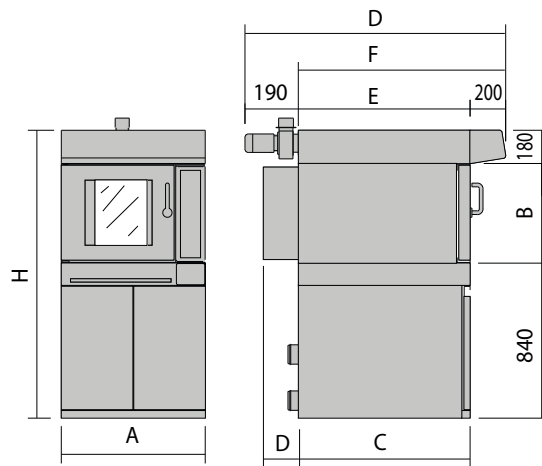

	A	B	C	D	E	F	G	H
	mm	mm	mm	mm	mm	mm	mm	mm
4060/5	780	540	930	190	930	1130	1320	1560
4080/5	780	540	930	430	1170	1370	1560	1560
4666/5	840	540	990	190	990	1190	1380	1560
6040/5	980	540	730	190	730	930	1120	1560
4060/10	780	1080	930	190	930	1130	1320	2100
4080/10	780	1080	930	430	1170	1370	1560	2100
4666/10	840	1080	990	190	990	1190	1380	2100
4060/9	840	1080	990	190	990	1190	1380	2100
6040/9	980	1080	730	190	730	930	1120	2100

		Pan capacity		Pan size	Minimum door width	Weight	Electrical power
		n°	passo	mm	mm	kg	kW
4060/5	FORNO Cell	5	78	400x600	550	100	6,5
		16	80	400x600	790	70	2,0
4080/5	FORNO Cell	5	78	400x800	550	120	8,5
		8	80	400x800	790	70	2,0
4666/5	FORNO Cell	5	78	400x600 460x660	550	120	8,5
		16	80	400x600 460x660	850	70	2,0
6040/5	FORNO Cell	5	78	600x400	550	100	8,5
		14	88	600x400	800	75	2,0
4060/10	FORNO Cell	10	89	400x600	790	180	13,0
		16	80	400x600	790	70	2,0
4080/10	FORNO Cell	10	89	400x800	790	200	17,0
		8	80	400x800	790	70	2,0
4666/10	FORNO Cell	10	89	400x600 460x660	850	200	17,0
		16	80	400x600 460x660	850	70	2,0
4060/9	FORNO Cell	9	89	400x600	850	200	13,0
		16	80	400x600	850	70	2,0
6040/9	FORNO Cell	9	89	600x400	1.000	180	17,0
		14	88	600x400	800	75	2,0